

PALO V SVILUPPO 113 PESI TEORICI	
SP1,2 mm	<b>Kg 1,07 /ml</b>
SP1,4 mm	<b>Kg 1,24 /ml</b>
SP1,5 mm	<b>Kg 1,32 /ml</b>
ZINCATURA A CALDO PER IMMERSIONE +10% DI SPESSORE E PESO	

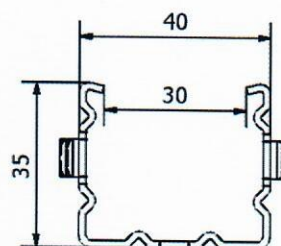

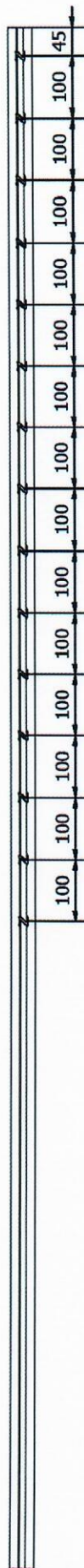
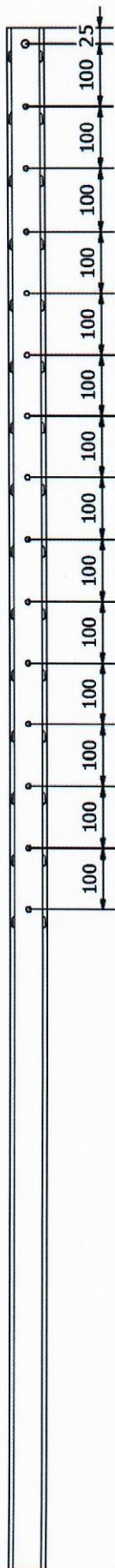

PALO V2 SVILUPPO 128 PESI TEORICI	
SP1,2 mm	<b>Kg 1,24 /ml</b>
SP1,4 mm	<b>Kg 1,45 /ml</b>
SP1,5 mm	<b>Kg 1,56 /ml</b>
SP1,8 mm	<b>Kg 1,85 /ml</b>
SP2,0 mm	<b>Kg 2,05 /ml</b>

ZINCATURA A CALDO  
PER IMMERSIONE +10%  
DI SPESSORE E PESO

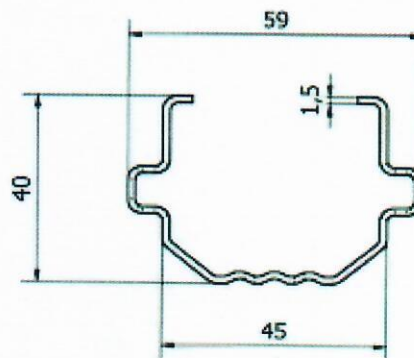

PALETTO ASOLA V2



**PREFABBRICATI VALTIDONE**  
*Pali e Accessori per Vigneti*

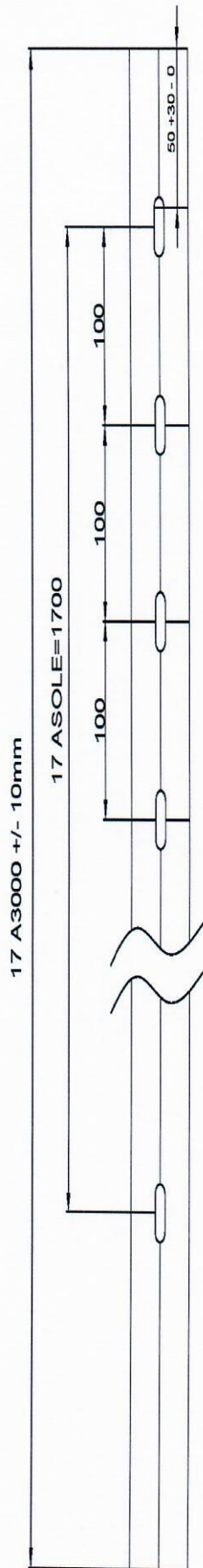

**PALO V2 TESTATA SVILUPPO 186  
PESI TEORICI**

SP1,5 mm	<b>Kg 2,10 /ml</b>
SP1,8 mm	<b>Kg 2,50 /ml</b>
SP2,0 mm	<b>Kg 2,70 /ml</b>
SP2,5 mm	<b>Kg 3,40 /ml</b>

ZINCATURA A CALDO  
PER IMMERSIONE +10%  
DI SPESSORE E PESO

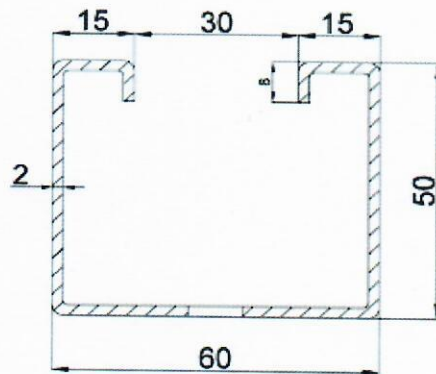

PALO CAPOTESTA V2



**PREFABBRICATI VALTIDONE**  
*Pali e Accessori per Vigneti*